

# SIMULATION OF UNIAXIAL TENSILE TEST THROUGH OF FINITE ELEMENT METHOD

João Baltar<sup>1</sup>  
Cleginaldo Carvalho<sup>2</sup>

## ABSTRACT:

With the globalization of companies and their respective products adding the necessity to minimize project costs, the technologies available in the market for product design and optimization have been used.

These technologies widely known today as Computer Aided Design (CAD) and Computer Aided Engineering (CAE), lead us to a refinement of the product to be developed globally with the company's activities.

In general, the Finite Element Method (FEM) is widely disseminated through computational analysis, but such popularization has turned out to be mere software users without proper analysis or theoretical knowledge of how a structure should behave due to the resulting forces applied in it.

In view of the exposed situations, it is necessary to resume the basic concepts of the FEM and then perform the analysis with the computational tool, allowing a more refined and safe analysis of the results presented by the structural calculation software.

Through this research proposal, it will perform a comparison between the uniaxial traction test and modeling of the same through FEM.

In other words, the subject of this paper is the adjustment of finite element model with simple uniaxial tensile tests.

Due to the easy reproducibility of the test results and resources available to the university, this work will contribute for further researches at the campus in Finite Elements Analysis approaches.

**Keywords:** Finite element method; tensile test; structural calculation; modeling.

## INTRODUCTION

In order to perform any destructive mechanical test, it is necessary to have reference values to guide the test in question, be it of uniaxial traction, torsion, impact and among others of the same nature.

When we do not have these values, whether they are intrinsic to the material to be tested or determined in technical standards, it is possible to adopt parameters such as the limits of flow and rupture through the values of surface hardness.

---

<sup>1</sup> Salesian University Center of São Paulo-UNISAL, Rua Dom Bosco 284, Lorena, São Paulo, Brazil. **E-mail:** joao.baltar@outlook.com

<sup>2</sup> School of Engineering of Lorena, University of São Paulo-EEL-USP, Estrada do Campinho S/N, Lorena, São Paulo, Brazil. **E-mail:** cleginaldopcarvalho@hotmail.com

The uniaxial tensile test was chosen because of its practicality and since several test specimens having the same characteristics and consequently the same chemical and mechanical properties can be obtained, this essay one of the most important. (SOUZA, 1982)

Because it is such a versatile test, it should be governed by standards that standardize the test, in order to ensure that the test method is universally the same.

After the practical mechanical analysis of the test specimens, a comparison will be made with the values provided in the raw material certificate, to validate the results obtained in the academic laboratory.

By compiling this information, you will begin with modeling/simulation using the Ansys Workbench® software, with the theoretical resistance data of the materials provided by the current standards.

## REVIEW

A pertinent question to this work is the fact of why not choose another raw material for this test. As for mechanical characteristics, this steel has a better performance in relation to, for example, ASTM A36 steel. When we acquire ASTM A572 Gr 50 steel in large proportions, it becomes viable and consequently we will have a higher quality raw material.

This is the most important moment for a designer engineer, because he is not only in charge of designing something that meets the customer's need and that he is available to pay for a certain solution, but also to estimate the cost of this equipment and life cycle of the same guaranteeing a sustainability of the product in the market, therefore, there is no point in having the best solution for the customer and the cost of this solution is unfeasible in relation to the prices practiced by the market.

For every project in question, we must work with input data whether it is physical, chemical or even empirical data.

In order to become an economically feasible project, not only real but also sustainable, for the applications every designer should have as premise to use commercially available materials.

In the case of machine and equipment designs, we have other factors / working conditions that influence the choice of the raw material to be used, and should not be limited to values of yield, strength or shear tension.

## METHODS

In this study, in a first moment we will discuss only the values of yield stress and rupture, since we adopted as standard the uniaxial tensile test, that is, we are conducting an experiment with values already known and that will serve as reference for the next steps this research.

Afterwards, the computational simulation of the uniaxial traction test will be developed and compared with the values obtained through the analytical method, considering that the results obtained in the tensile test were higher than the normalized values for this material.

## STANDARD PROPERTIES

As a standard, ASTM A572 / A572M is itself a nomenclature of steel, provides us with the chemical composition of the steel as shown in Table 1 and also gives us the values of yield strength and rupture according to the degree of steel.

**Table 1.** Chemical properties required from standard.

Grade	Carbon, max, %	Manganese, max %	Phosphorus, max, %	Sulfur, max. %	Silicon %	Niobium %	Vanadium %
50 [345]	0,23	1,35	0,03	0,03	0,15 – 0,40	0,005 – 0,05	0,01 – 0,15

The test specimens that will be analyzed in this study come from an ASTM A572 Gr 50 plate, where through Table 2 we can see the respective resistance values standardized for this material, that is, when supplied the raw material itself should have at least these values of resistance.

**Table 2.** Tensile requirements

Grade	Yield Point, min		Tensile Strength, min		Minimum Elongation, % <sup>B,C,D</sup>	
	ksi	[MPa]	ksi	[MPa]	in 8 in. [200 mm]	in 2 in. [50 mm]
42 [290]	42	[290]	60	[415]	20	24
50 [345]	50	[345]	65	[450]	18	21
55 [380]	55	[380]	70	[485]	17	20
60 [415]	60	[415]	75	[520]	16	18
65 [450]	65	[450]	80	[550]	15	17

<sup>A</sup> See specimen Orientation under the Tension Tests section of Specification A6/A6M.

<sup>B</sup> Elongation not required to be determined for floor plate.

<sup>C</sup> For wide flange shapes over 426 lb/ft [634 kg/m], elongation in 2 in. [50 mm] of 19 % minimum applies.

<sup>D</sup> For plates wider than 24 in. [600 mm], the elongation requirement is reduced two percentage points for Grades 42, 50, and 55 [290, 345, and 380], and three percentage points for Grades 60 and 65 [415 and 450]. See elongation requirement adjustments in the Tension Tests section of Specification A6/A6M.

ASTM A572 / A572M standard only determines the chemical and mechanical requirements of the material. The parameters of how to carry out the assays that ensure the quality of the material follow according to ASTM A370.

## MATERIAL PROPERTIES AS RECEIVED

As a benchmark to ensure the quality of the material and equipment being used to perform the test, the boilermaker was asked to provide us with the quality certificate provided by the plant.

For every steel run produced by the mill, tests are performed to ensure that steel meets the required standards, so we will assume that these values will be the control to ensure that the values obtained in the test performed are reliable.

We can verify these values on Table 3 and Table 4.

**Table 3.** Chemical requirements and alloy steel from supplier.

C	Mn	P	S	Si	Al	Cu	Mo	Cr	Ni	Nb	V	Ti	N
0,12	1,29	0,023	0,005	0,166	0,049	0,010	0,001	0,018	0,009	0,029	0,003	0,020	0,0042

**Table 4.** Test specimens results from supplier.

Test specimen / Properties	1	2
Yeld Point (Mpa)	407,7	475,2
Tensile Strength (Mpa)	508,80	534,00
Yeld point/Tensile strength (%)	80	89
Elongation (%)	29	23

## PROCEDURE

After the drawings were made available, according to the standard established for this project, a heavy equipment company located in the Paraíba Valley was requested to provide the raw material.

Continuing the necessary steps to carry out the tensile test, with the support of the educational institution, the machining of the test specimens was granted in the mechanical laboratory.

The KRATOS universal test machine - Model KE 30,000 MP - Serial No.: M14031234 with load capacity of 30,000 (kgf) and current calibration certificate was used for the tensile test. It is available for students' use at the teaching institution, located in the mechanical laboratory.

Relevant point to be considered, that up to the present moment, the machine had not been used for the elaboration of tests that are part of a research of technological initiation.

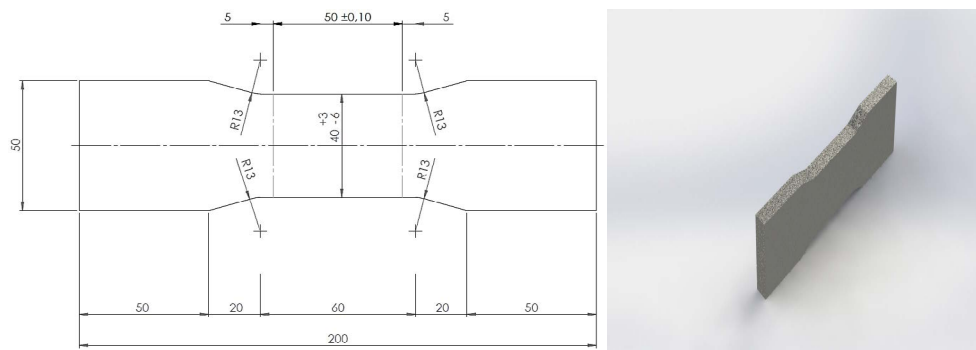

Figure 1. Main dimensions of test specimen.

## RESULTS AND COMENTS

### CONVENTIONAL UNIAXIAL TENSILE TEST

Eight test specimens were tested, according to the norms previously described as premises of this project. We can verify these conditions trough Table 5:

Table 5. Results of the uniaxial traction test specimens.

Test specimens / Properties.	1	2	3	4	5	6	7	8	Average
Yeld point (Mpa)	463,13	457,50	442,50	438,75	450,00	452,50	436,25	436,25	447,11
Tensile strength (Mpa)	500,74	496,91	474,85	471,61	496,91	497,50	471,02	469,84	484,92
Yeld point/Tensile strength (%)	92	92	93	93	91	91	93	93	92
Standard length (mm)	50,00	50,00	50,00	50,00	50,00	50,00	50,00	50,00	50,00
Linear elongation (mm)	59,72	59,6	57,09	58,6	61,76	59,89	58,63	58,15	59,18
Elongation (%)	19,44	19,20	14,18	17,20	23,52	19,78	17,26	16,30	18,36

### SIMULATION OF THE TRACTION TEST THROUGH THE FEM

As evidenced in the uniaxial tensile test, the material supplied has characteristics superior to those required in relation to the standard thereof.

For engineering and simulation criteria, the theoretical values of flow and rupture limits determined in the current standards were considered.

By performing the static simulation in the Ansys Workbench®, we chose to work in the elastic zone of the material, where it presents a linear behavior, facilitating the comparison with the analytical method.

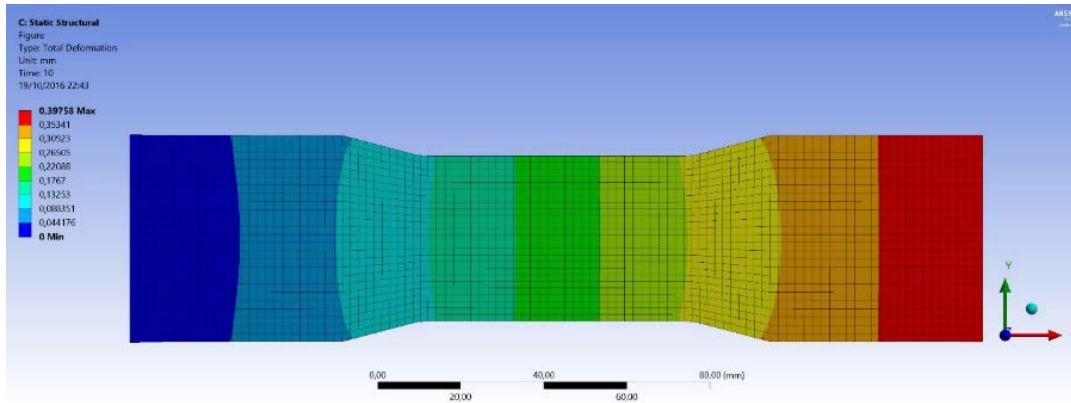

**Figure 2.** Total deformation of CDP through static structure analysis.

## ANALYTICAL METHOD

As we adopt for analysis the elastic region of the curve of the previously described material, whose region presents a linear behavior, we will apply the Hooke's Law, which it describes in a linear form the relation between tension and deformation.

This relationship between stress and strain can be described by the Equation 1:

$$\sigma = E \times \varepsilon \quad (1)$$

Where:

- $\sigma$  - tension (MPa);
- $E$  - modulus of elasticity (GPa);
- $\varepsilon$  - specific (dimensionless) deformation;

The Equation 2 can describe the specific deformation:

$$\varepsilon = \frac{\delta}{l_0} \quad (2)$$

Where:

- $\delta$  - deformation or total elongation, can also be described as  $\Delta l$  (mm);
- $l_0$  - initial length (mm)

We also know that the tension can be described as shown by Equation 3:

$$\sigma = \frac{F}{A} \quad (3)$$

Where:

- F – force (N);
- A – area (mm<sup>2</sup>);

Correlating Equations 1, 2 and 3, we can describe the total deformation through Equation 4:

$$\delta = \frac{F \times l_0}{A \times E} \quad (4)$$

Now with these definitions we can proceed to the study in question, below follows the Table 6 with the values compiled according to the parameters adopted in the uniaxial traction test.

**Table 6.** Values obtained through analytical method.

Period	Force (kN)	$\sigma$ (MPa)	$\delta$ (mm)	$\epsilon$ (mm/mm)
T0	0,00	0,00	0,00000	0,000000
T1	12,50	25,00	0,00625	0,000125
T2	25,00	50,00	0,01250	0,000250
T3	37,50	75,00	0,01875	0,000375
T4	50,00	100,00	0,02500	0,000500
T5	62,50	125,00	0,03125	0,000625
T6	75,00	150,00	0,03750	0,000750
T7	87,50	175,00	0,04375	0,000875
T8	100,00	200,00	0,05000	0,001000
T9	112,50	225,00	0,05625	0,001125
T10	125,00	250,00	0,06250	0,001250
T11	137,50	275,00	0,06875	0,001375
T12	150,00	300,00	0,07500	0,001500
T13	162,50	325,00	0,08125	0,001625
T14	172,50	345,00	0,08625	0,001725

## ANALYSIS OF RESULTS SIMULATION VS. ANALYTICAL METHOD

It is then possible to compare the values obtained through the simulation and the calculations.

The relative error was defined below by Equation 5:

$$\text{Relative error} = \frac{\text{Calculated value} - \text{Simulated value}}{\text{Calculated value}} \times 100\% \quad (5)$$

**Table 7.** Comparison of tensions.

	Simulated	Calculated	
Period	$\sigma$ (MPa)	$\sigma$ (Mpa)	Relative error
T0	0,00	0,00	0,00%
T1	24,98	25,00	0,07%
T2	49,70	50,00	0,60%
T3	74,35	75,00	0,87%
T4	98,82	100,00	1,18%
T5	123,70	125,00	1,04%
T6	149,03	150,00	0,64%
T7	172,48	175,00	1,44%
T8	198,26	200,00	0,87%
T9	223,81	225,00	0,53%
T10	246,98	250,00	1,21%
T11	271,62	275,00	1,23%
T12	296,31	300,00	1,23%
T13	319,75	325,00	1,61%
T14	343,36	345,00	0,48%

**Table 8.** Comparison of total deformation.

	Simulated	Calculated	
Period	$\delta$ [mm]	$\delta$ [mm]	Relativ error
T0	0,0000000	0,0000000	0,00%
T1	0,0061608	0,0062500	1,43%
T2	0,0123220	0,0125000	1,42%
T3	0,0184830	0,0187500	1,42%
T4	0,0246430	0,0250000	1,43%
T5	0,0308040	0,0312500	1,43%
T6	0,0369650	0,0375000	1,43%
T7	0,0431260	0,0437500	1,43%
T8	0,0492870	0,0500000	1,43%
T9	0,0554480	0,0562500	1,43%
T10	0,0616080	0,0625000	1,43%



	Simulated	Calculated	
Period	$\delta$ [mm]	$\delta$ [mm]	Relativ error
T11	0,0677690	0,0687500	1,43%
T12	0,0739300	0,0750000	1,43%
T13	0,0800910	0,0812500	1,43%
T14	0,0850200	0,0862500	1,43%

**Table 9.** Comparison of specific deformations.

	Simulated	Calculated	
Period	$\delta$ [mm]	$\delta$ [mm]	Relativ error
T0	0,0000000	0,0000000	0,00%
T1	0,0001232	0,0001250	1,43%
T2	0,0002464	0,0002500	1,42%
T3	0,0003697	0,0003750	1,42%
T4	0,0004929	0,0005000	1,43%
T5	0,0006161	0,0006250	1,43%
T6	0,0007393	0,0007500	1,43%
T7	0,0008625	0,0008750	1,43%
T8	0,0009857	0,0010000	1,43%
T9	0,0011090	0,0011250	1,43%
T10	0,0012322	0,0012500	1,43%
T11	0,0013554	0,0013750	1,43%
T12	0,0014786	0,0015000	1,43%
T13	0,0016018	0,0016250	1,43%
T14	0,0017004	0,0017250	1,43%

## CONCLUSION

When analyzing the simulation of the test by FEM, we must consider which variables and which boundary conditions we want to act on the analyzed bodies, not only to simulate and accept the values obtained.

For the analysis of both stresses and total displacements, when the test specimen is considered as a global analysis, it is possible to obtain an erroneous reading of the results when compared to the analytical result.

This question arises, due to the study when performed through the analytical method, despite analyzing a section, we end up assuming that section is infinite, that is, the values obtained for that section are absolute and consequently we can commit the mistake of disregarding the behavior of the model in other sections.

When the FEM is used, the name of the method already defines it, it analyzes the model in a finite form, that is, the software considers, either efforts or displacements in all the

sections available for the analyzed model, so if not interpreted from When there is the analogy to the analytical data, there will be significant divergences from the simulated values over the calculated ones.

Therefore, it was adopted as a research strategy, the analysis only in the section where the test body is constrained, where  $l_0$  is determined by norm and consequently all other values obtained are related to this region of the test specimen.

In relation to the presented results, we can conclude that they were satisfactory assuming that the model analyzed in a macro and micro (section  $l_0$ ) did not have a specific work of mesh refinement, but both had the same characteristics.

We must also consider that the relative error of a global form, we can consider satisfactory, because the obtained values were briefly smaller than those calculated, reinforcing that if there is a refinement of the meshes it would be possible to minimize this relative error.

We must also consider that the relative error of a global form, we can consider satisfactory, because the obtained values were briefly smaller than those calculated, reinforcing that if there is a refinement of the meshes it would be possible to minimize this relative error.

Another important point to note is that this type of analysis really brings great benefits to engineering departments and even the development and research of new products due to their versatility, reliability, repeatability and consequently helps in the validation of new projects, minimizing the number of prototypes consequently reduce costs in the development of new products.

As suggestions for future work, it is recommended the analysis with refinement of the meshes for the working regime in the elastic zone and how it would be the same in the plastic zone applying the dynamic study.

## REFERENCES

Abbassi, Fethi, et al. *An Experimental and Numerical Study of Necking Initiation in Biaxial Tensile Test*.

Alves filho, Avelino. 2000. *Elementos Finitos: A Base da Tecnologia CAE*. São Paulo : Érica, 2000. p. 160.

American society for testing and materials. 2015. *ASTM A370: Standard Test Methods and Definitions for Mechanical Testin of Steel Products*. 2015.

—. 2015. *ASTMA572/A572M: Standard Specification for High-Strength Low-Alloy Columbium-Vanadium Structural Steel*. 2015.

- . 2014. *ASTM A6/A6M: Standard Specification for General Requirements for Rolled Structural Steel Bars, Plates, Shapes, and Sheet Piling*. 2014.
- Cabezas, Eduardo E. e Celentano, Diego J. 2004. "Experimental and numerical analysis of the tensile test using sheet specimens." *Finite Elements in Analysis and Design*. 2004, Vol. 40, 5, pp. 555-575.
- Callister, William D. 2002. "Ciência e engenharia dos materiais: uma introdução." Rio de Janeiro : LTC, 2002. Vol. 5 ed.
- Franceschi, Alessandro de e Antonello, Miguel Guilherme. 2014. "Elementos de máquinas." Santa Maria : e-Tec Brasil, 2014. p. 152. 978-85-63573-61-2.
- Garcia Garino, Carlos, Galbadón, Felipe e Goicolea, José M. 2006. "Finite element simulation of the simple tension test in metals." *Finite Elements in Analysis and Design*. Setembro de 2006, Vol. 42, pp. 1187-1197.
- Hibbeler, Russel Charles. 2010. "Resistência dos Materiais." 7ª. São Paulo : Pearson Prentice Hall, 2010. p. 642.
- Lotti, Raquel S., et al. 2006. "Aplicabilidade científica do método dos elementos finitos." *R Dental Press Ortodon Ortop Facial*. Março/Abril de 2006, Vol. 11, 2, pp. 35-43.
- Marques, Mário Sérgio Silva. 2014. "Análise Estrutural de um Pórtico Rolante Conforme as Normas NBR 8400 e NBR 10084 Usando o Ansys Workbench." *Instituto ESSS de Ensino, Pesquisa e Desenvolvimento*. São Paulo : s.n., 2014. p. 58, Títulos de Especialista em Análise Numérica Estrutural.
- Souza, Sérgio Augustode. 1982. "Ensaio Mecânicos de Materiais Metálicos: Fundamentos teóricos e práticos." 5ª. São Paulo : Blucher, 1982. p. 286.

**Recebido em: 06/10/2017**

**Aceito em: 19/12/2017**